

Posts are the foundation to a well built fence.
A solid foundation means a safer, stronger,
longer lasting, better looking fence.

Remember this when thinking about posts:

Bigger – Deeper – Longer – Stronger

End or Corner Posts: General Rules

Setting End and Corner Posts is the key to a quality installation of high-tensile polymer fence.

- It is recommended to only use CCA pressure treated posts.
- Concrete footings need to extend below the frost line.
- Concrete footings for the upright End Posts and Corner Posts must be bell-shaped.
- Diagonal brace footing is always faced off.

Tips & Techniques

- 1 Bigger, Deeper, Longer, Stronger:** Increase the diameter of all end, gate, and 90 degree corner posts from the standard 6" (152mm) to an 8" (203mm) minimum. This will lessen the number of failures and loss of fence tension. The reason is that over time and especially in moist soil, below the ground line, the smaller diameter end and corner posts bow and knife through the soil being pulled in the same direction by both the brace cable and the fence itself. Movement of up to 4" (102mm) has been observed. Other countries of the world use larger diameter posts because of this hidden problem. Australia for instance uses mainly 12" (305mm) and larger.
- 2 Proper Lean:** There should be one inch of lean against the pull of the wires from the top post, 4.5' (137cm) to the ground line prior to tensioning the fence. Use a measuring level, torpedo level or plumb-bob to assist. If too much lean then keep lighter tension on the brace cable. Remember once there is tension on the end post it is impossible to retighten ANY brace cable or brace wires, without letting off tension on the fence first.
- 3 First Things First:** Always position brace cable starting at the base of all end, gate and corner posts, then to the top of the brace post when using a top horizontal member of either a 4.5' (137cm) x 10' (305cm) pressure treated post or a 2" (51mm) x 10' (305cm) (SS20) galvanized pipe.

- **WARNING: Only for use with low-impedance electric fence energizers!**
- **Always use an adequate number of electric fence warning signs and make sure to attach them securely.**
- **It's essential to keep fence line clear of all debris. Please do not burn!**

Corner Posts

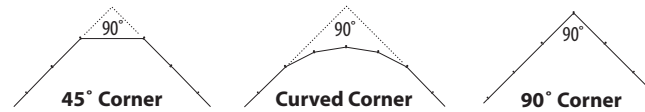

Possible Corner Designs:

All designs can have the fence on either the inside or outside of the posts.

NOTE: It is safer to install the fence on the inside toward horses.

Curved Corner

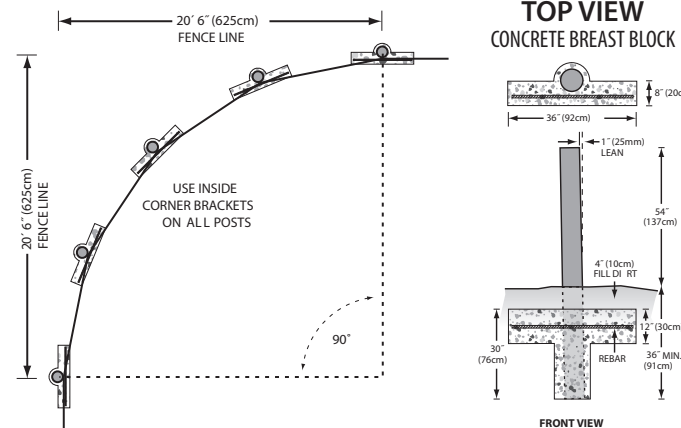

Hottop® Inside Corner

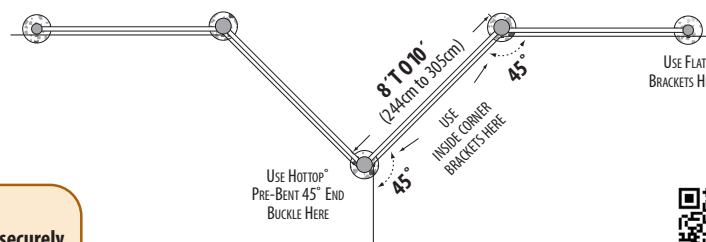

45° Corner

45° Corner – Horizontal Brace

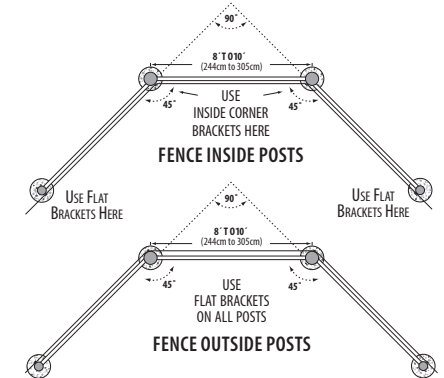

45° Corner – Diagonal Brace

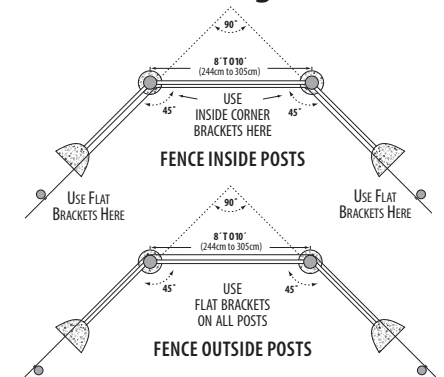

For More Details, Tips & Techniques on Building Fences, Please visit our website:



horserrail.com

Copyright © 2021 John Wall, Inc. All Rights Reserved. Horserrail®, Hottop®, Hottop Plus®, Horsecote®, Hotcote®, and Safe-T-Brace Cable® are registered U.S. trademarks of John Wall, Inc. Please visit horserrail.com for a complete list of trademark and patent information.

Hardware is Double Coated for Superior Weather Resistance: E-Coat and Powder Coat



SAFETY FIRST: USE SAFETY EYE GLASSES AND GLOVES.

Safe-T-Brace Cable®

Made from Pre-Straightened High Tensile Wire with Curved Radius On The Pre-Bend and Twisted for Superior Strength!

- PRE-ASSEMBLED KIT
- SAVES TIME
- SUPER STRONG
- LONG LIFE
- VERY SAFE
- NO ENTRAPMENT
- NO PINCH-POINT
- SO CONVENIENT

Kit Includes:

- Four 16' (488cm) Twisted Strand High Tensile Brace Wire for 10' (305cm) Top Horizontal Brace
- One Mini Spooler: (with locking pins)
- Three 1.5" (38mm) Staples

Optional Safety Pipe

- 8.5' to 9' (260cm to 274cm) long 3/4" (19mm) min. OD electric conduit or rigid PVC (Paint to match your fence)
- 3/4" (19mm) diameter allows for air flow to dry off moisture, otherwise white rust may occur
- Added safety provided when pipe rolls as horse rubs against it, preventing direct contact with cable

Tools Required

- Hammer
- Horserail® 2" (5cm) Extended Handle w/Ratchets

1 End Post Assembly

- Place the loop end of the brace cable around the end post from the wire or rail side of the fence.
- Position the loop near the inside, center line of the post. Orient the loop for ease of lacing. Staple cable to post 6" (15cm) up from the ground line and within 4" (10cm) from the loop.
- Lace the other end of the brace cable through the loop as though you are lassoing the end post, pull the brace cable all the way through loop until taut - then manually bend the cable at the loop end to hold in place.

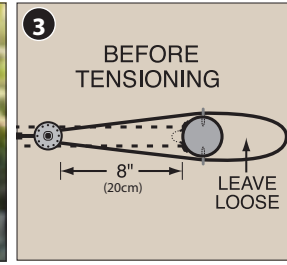

2 Added Safety Pipe (Optional)

- Slide on an 8.5' (260cm) to 9' (274cm) long piece of 3/4" (19mm) min. OD electric conduit or rigid PVC, painted to match your fence.

3 Brace Post Assembly

- Slide on the Mini Spooler.
- Hammer a staple on both sides of the brace post under where the rail bracket or wire will be positioned.
- Slide the cable end through one staple and back around the brace post through the other staple.

4 Tensioning Mini Spooler

- Place both ratchets into the Mini Spooler hubs. (top and bottom)
- Slide the Horserail® 2" (5cm) Extended Handle onto the ratchets.*
- Pull the Handle (don't push) to tension the cable. With your hand - carefully hold the Mini Spooler to stop it from unwinding. Ratchet

back the Handle, release the Mini Spooler and pull again, then hold the Mini Spooler, repeat this process until taut.

- Lean into the Handle with your body while inserting both locking pins - locate pins in opposite holes - closest to the cable brace.

* **Note:** The above tensioning techniques are for a one man installation using a Horserail 2" (5cm) Extended Ratchet Handle. In a two man installation, one man could use two 24" (60cm) Long Handled Ratchets while the other man sets the locking pins.

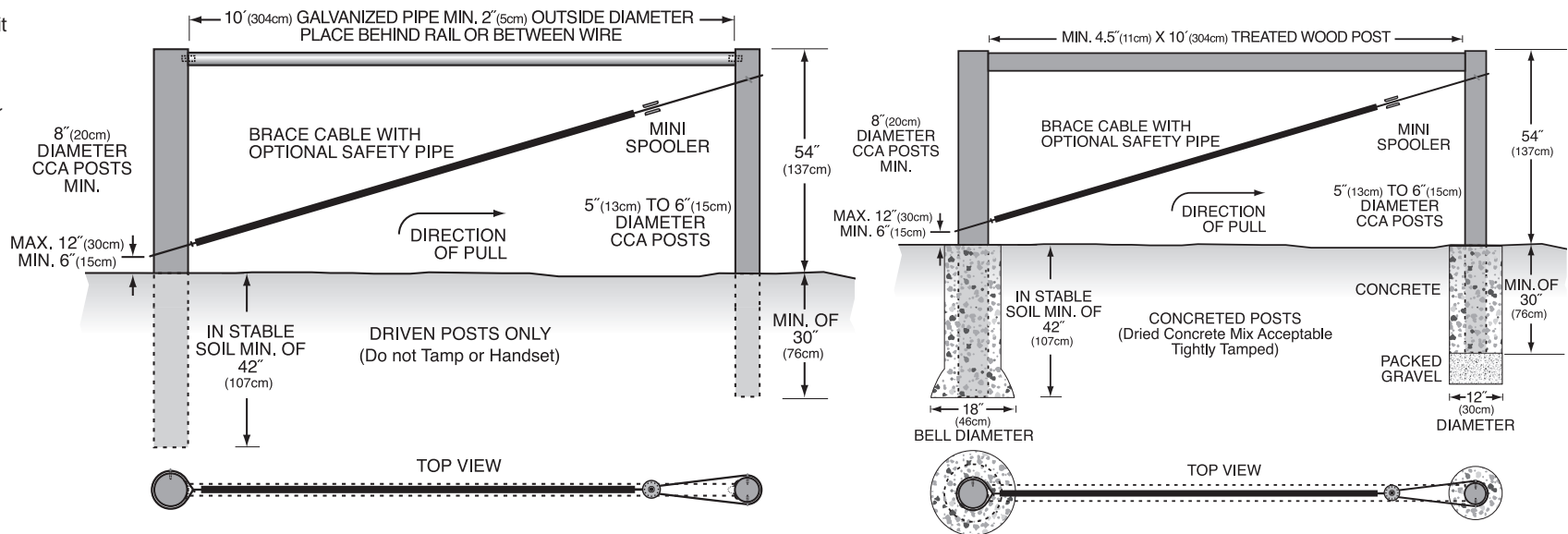

NO BRACE END POST

A no brace end, gate or corner post for tensioned fence materials for horses, such as Horserail®, Hottop® and Hottop®Plus

This is a single post end but it needs the following...

Essential conditions and materials for this to work.

- ❶ Soil conditions that allows you to auger up to 7.5' (228cm) deep by 16" (40cm) diameter hole, less if it is super stable, rocky conditions.
- ❷ Having an auger with rock teeth and an extension that has down pressure and can drill that deep.
- ❸ Or finding a contractor that has the equipment to drill such a hole at a fair price.
- ❹ Having access to 10" – 12" x 12' [(25cm – 30cm) x 365cm] treated poles (*even used*). Making sure to coat the exposed cut surface with roofing sealer material. Suitability of used poles can be determined by density and sound when hit with a hammer as to how solid they are.
- ❺ Making up or having access to a 10' (304cm) long handled tamping bar (*rammer*) and a utility scoop shovel for cleaning bottom of hole.
- ❻ Willing to mix up the ingredients to make the equivalent of 5 bags of dry concrete mix (321)*, or purchase same, for each hole, 1 bag in the bottom, then soil tamped tightly in small increments to within 36" (914mm) of the ground line, more dry concrete mix tamped tight to within 6" (152mm), finish out with sod. Allow soil moisture to set up, and don't final tension fence until it has set.

With the above you have the capacity to build yourself a one post end that can handle a tensioned Horserail® fence without bracing, giving you "a clean board look."

When this is not practical to build then the standard single brace assembly with a top horizontal of 10' (304cm) and a covered Safe-T-Brace® Cable kit will be more than strong enough – *especially if an HD post driver is used.*

When that is not an option, one can auger a 3.5' minimum x 16" (1067mm min. x 406mm) hole and use concrete to set the posts.

Detailed information available on horserail.com.

**Note: Dry concrete mix is considered porous, allows water to escape, treated posts last longer.*

In softer soils - use a buried breast-block or a flat face for the concrete.

Lean post 1" (25mm) against pull of fence.

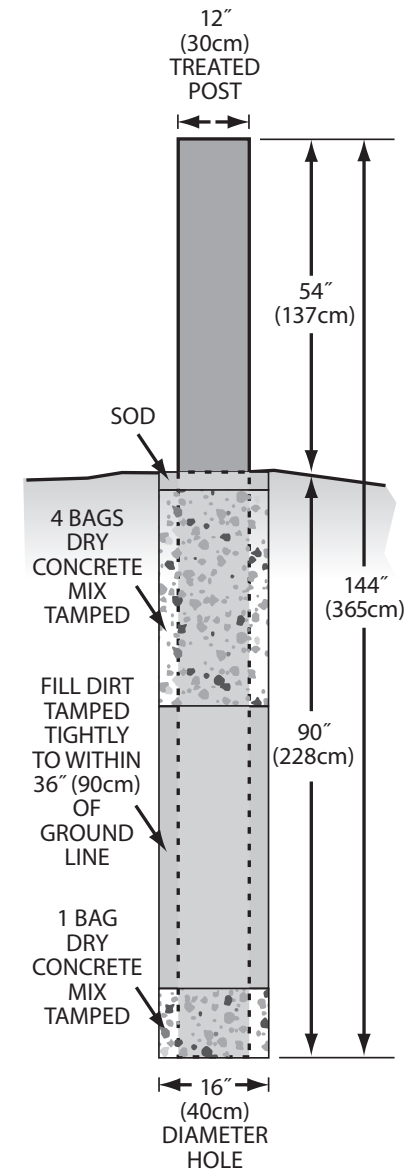

HAND-SET END OR GATE POSTS

Side View of a Hand-Set End Post with Horizontal Bracing for Added Strength (Augered Holes)

- A** Depth of concrete may vary according to frost lines in your area. Consult local codes.
- B** Lean post 1" (25mm) away from direction of pull.
- C** To stop upward lift - the footing must be bellbottomed all the way around. 24" (60cm) bell diameter is recommended in unstable soil. It is recommended to auger a 16" (40cm) diameter hole, 3' (91cm) deep with a bell in the northern states and a 4' (122cm) deep in Canada.

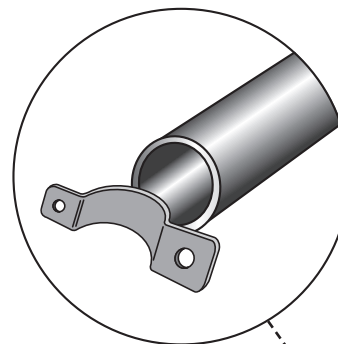

Pipe Bracket and Brace Pipe attach to post with screws or staples.

This method of attachment stops the pipe from compressing into the soft pine post.

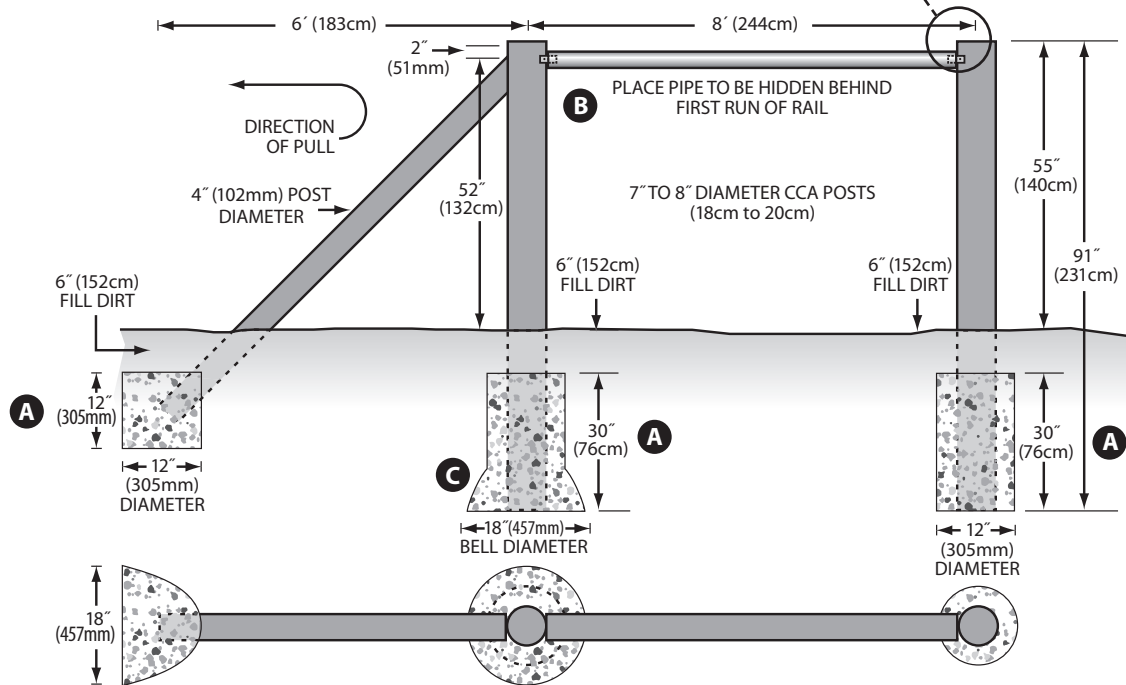

SAFETY FIRST: USE SAFETY EYE GLASSES AND GLOVES.